

# DUO CAN 1



Copyright © 2006-2007, FORTIN AUTO RADIO INC. ALL RIGHTS RESERVED

# INSTALLATION GUIDE

Made in Canada - Rev. C - 17 / 09 / 2008  
Web site: <http://www.ifar.ca>

## ALARM AND REMOTE STARTER CAN BUS INTERFACE KIT



### WIRING / CONNECTION GUIDE

See wiring schematic configuration

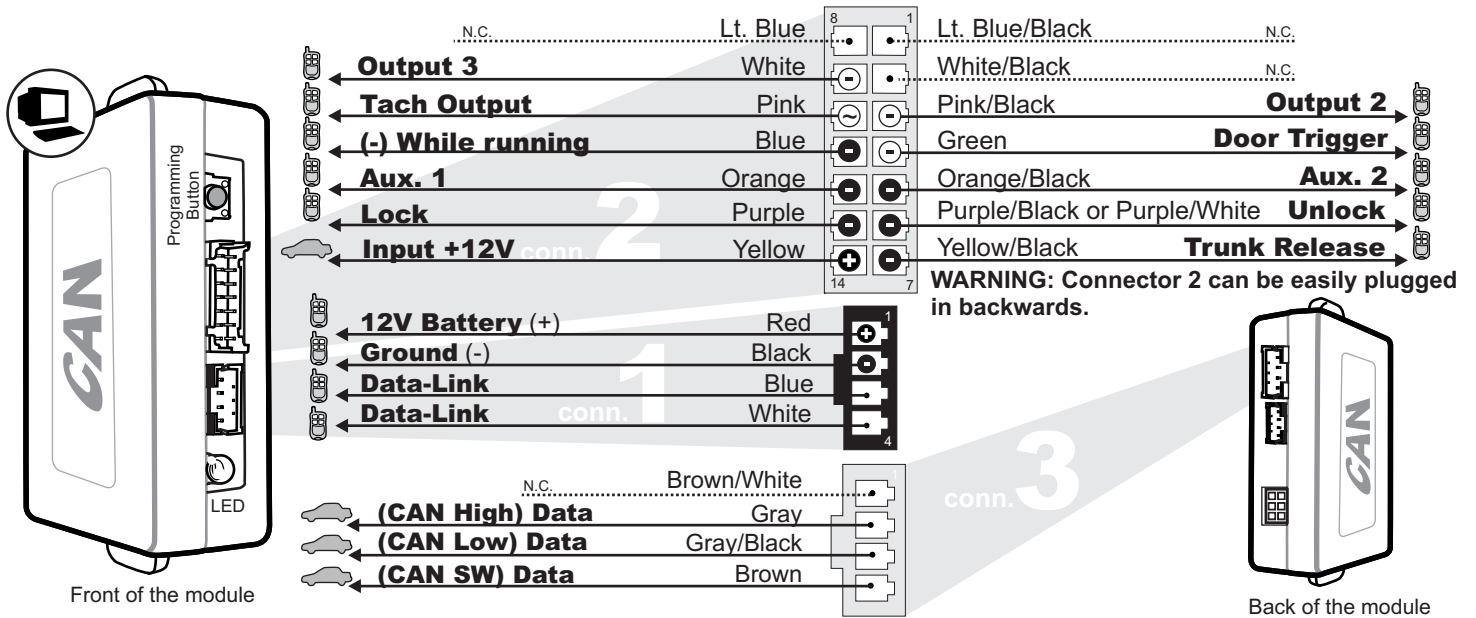

### WIRING / CONNECTION GUIDE

See wiring schematic configuration

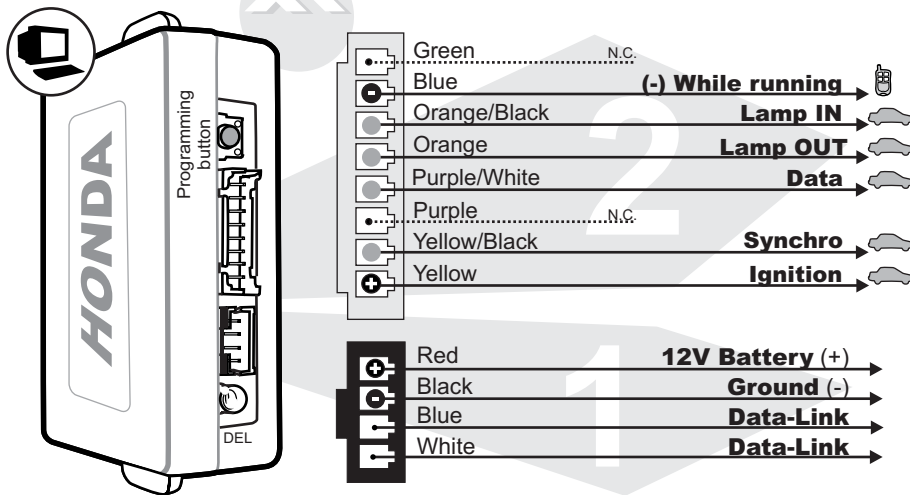

Connect wire to vehicle  
Connect wire to Remote-Starter/Alarm

● INPUT  
○ OUTPUT

### TECHNICAL SUPPORT / INFORMATION

Neither the manufacturer or distributor of this module is responsible of damages of any kind indirectly or directly caused by this module, except for the replacement of this module in case of manufacturing defects. This module must be installed by qualified technician. This instruction guide may change without notice. Visit [www.ifar.ca](http://www.ifar.ca) to get latest version.

**Technical support:**  
TEL: 514-255-HELP (4357)  
FAX: 514-255-1367  
Web: [www.ifar.ca](http://www.ifar.ca)

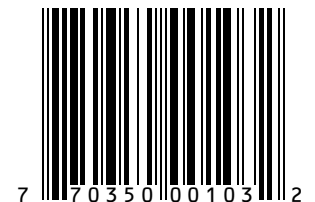



## MODULE D'INTERFACE CAN BUS POUR ALARME ET DÉMARREUR À DISTANCE



### CÂBLAGE / GUIDE DE CONNEXION

Voir SCHÉMA DE BRANCHEMENT

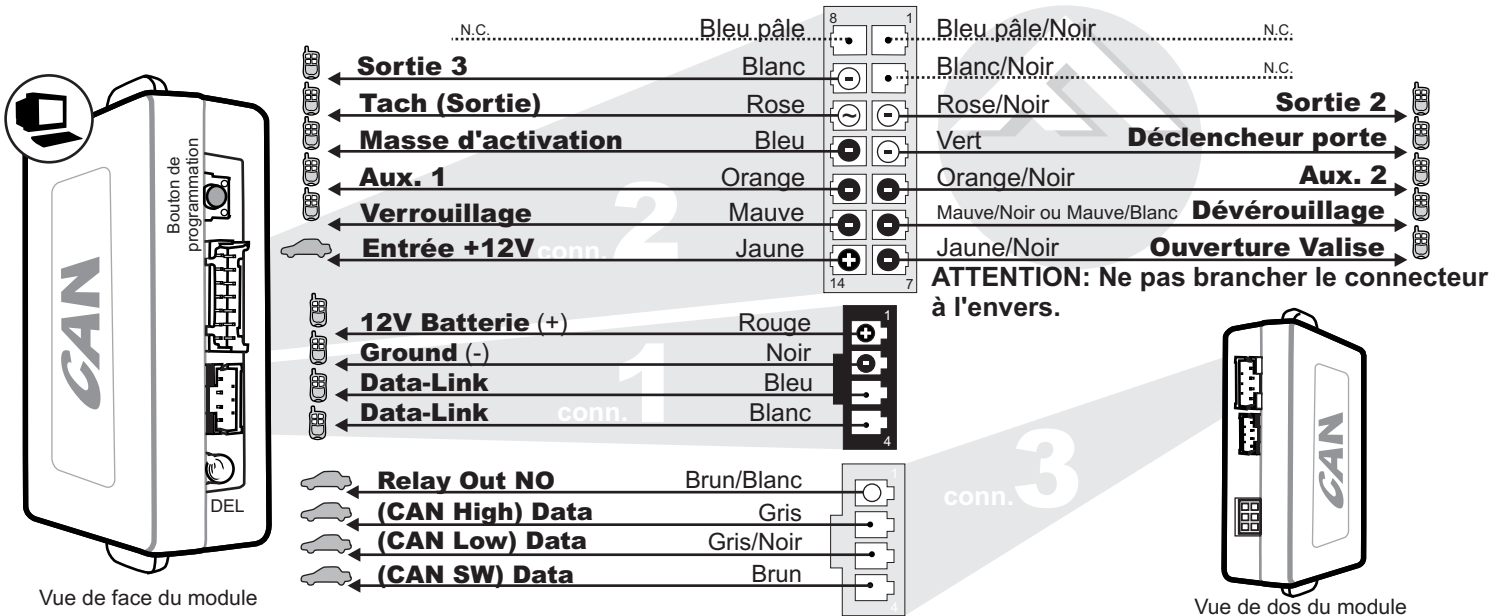

### CÂBLAGE / GUIDE DE CONNEXION

Voir SCHEMA DE CONFIGURATION

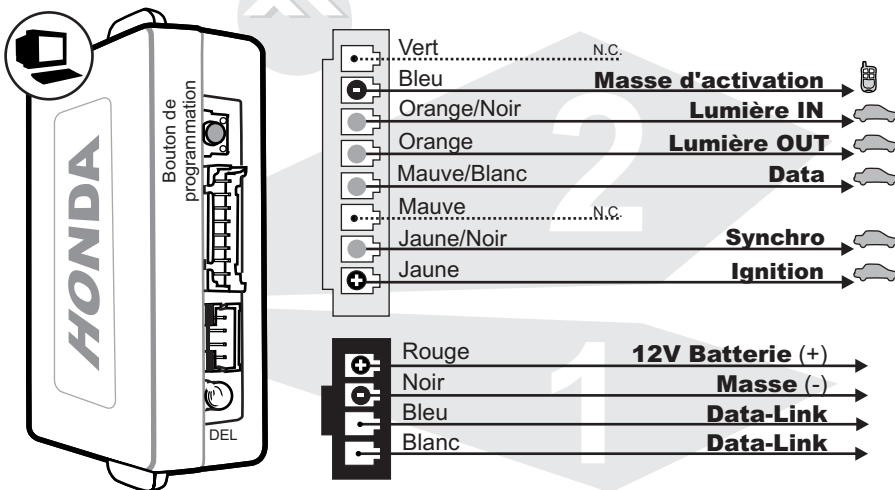

MISE À JOUR  
PAR INTERNET!



Branchement du filage  
au démarreur à distance/Alarmer



Branchement du filage au véhicule



SORTIE



ENTRÉE

### INFORMATIONS / SUPPORT TECHNIQUE

Ni le fabricant, ni le distributeur ne se considèrent responsables des dommages causés ou ayant pu être causés, indirectement ou directement, par ce module, excepté le remplacement de ce module en cas de défectuosité de fabrication. Ce module doit être installé par un technicien qualifié. Ce guide d'instruction peut faire l'objet de changement sans préavis. Consultez le [www.ifar.ca](http://www.ifar.ca) pour voir la plus récente version.

**Support Technique:**  
TEL: 514-255-HELP (4357)  
FAX: 514-255-1367  
Web: [www.ifar.ca](http://www.ifar.ca)





## VEHICLE FIT GUIDE | GUIDE DES VEHICULES

Vehicles Véhicules	Years Années	Fonctionnel if equipped   Fonctionnelle si le véhicule en est équipé.																Wiring Schematic Configuration   Schémas de branchement									
		Verrouillage Lock	Déverrouillage Unlock	Armeement Arms	Désarmeement Disarms	Téléclé Tunk	Tach	Future option	Système des des portes Door 1 trigger	Système des des portes Door 2 trigger	Système des des portes Trunk trigger	Hood trigger Hood trigger	Radio Off	Transpondeur ByPass	Passlock PKC	Portes coulissantes Sliding doors	Dégivrage Defrost	Dégivrage Defrost	Sièges chauffants Heat Seats	Capotons Gas door	Roll Down *Window	Hayon arrière Hatch	MODULE CAN MODULE	MODULE HONDA MODULE			
<b>Acura</b>	02 03 04 05 06 07 08																										
MDX																									2	5	
RL																									2	4	
TL																									1	4	
TSX																									1	4	
<b>Honda</b>	02 03 04 05 06 07 08																										
Accord																									1	4	
Accord Hybrid																									3	6	
Odyssey																									1	4	
Ridgeline																									2	4	
																									1	4	

This Vehicle Fit Guide may change without notice. Visit [www.ifar.ca](http://www.ifar.ca) to get latest version.

Ce Guide des véhicules peut faire l'objet de changement sans préavis. Consultez le [www.ifar.ca](http://www.ifar.ca) pour voir la plus récente version.

\*\* : Ouverture des fenêtres (Window roll down).

## WIRING SCHEMATIC CONFIGURATION | SCHÉMA DE BRANCHEMENT

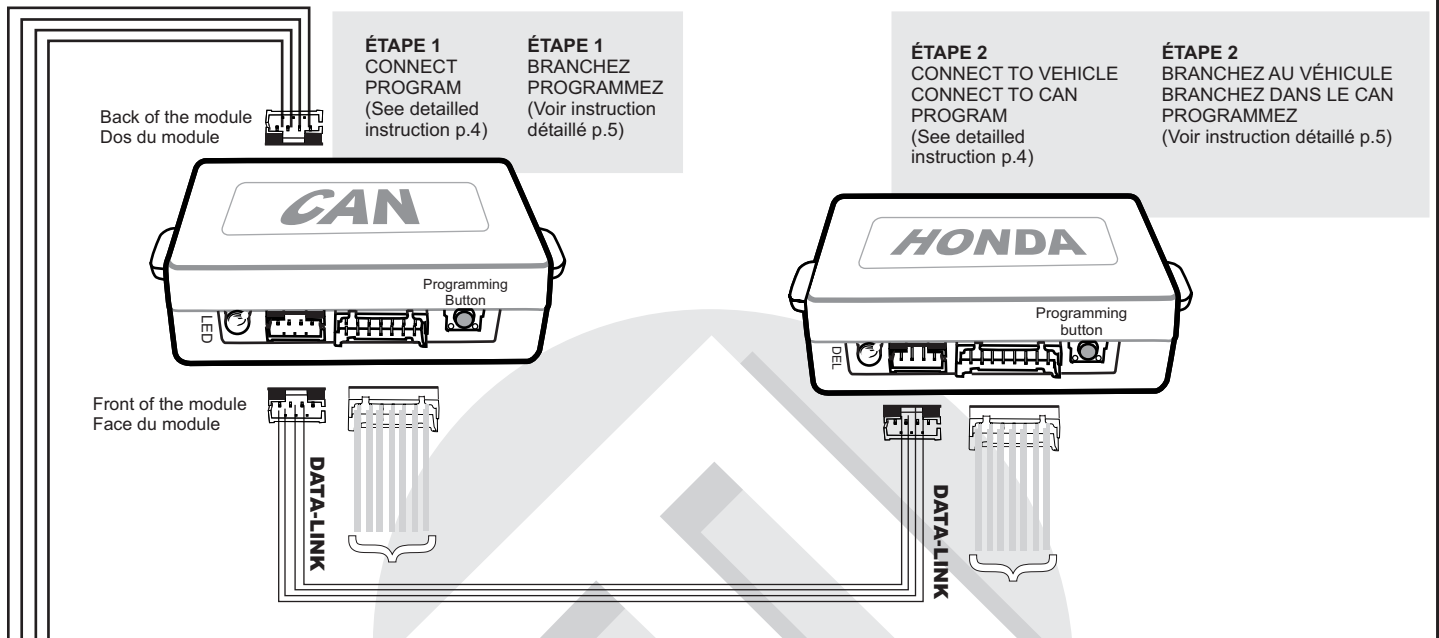

### INSTALLATION WITH DATA-LINK INSTALLATION SUR SYSTÈME AVEC DATA-LINK

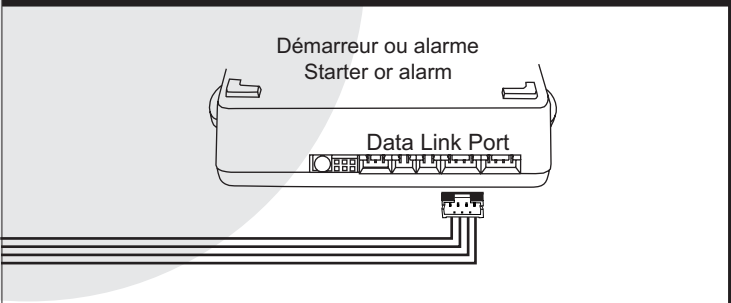

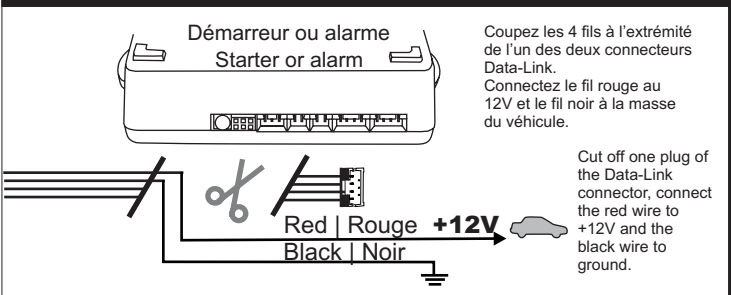

### INSTALLATION WITHOUT DATA-LINK INSTALLATION SUR SYSTÈME SANS DATA-LINK





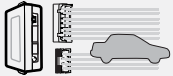

## INSTALLATION AND PROGRAMMING INSTRUCTIONS

**1**  **Make the connections of the CAN to the vehicle:**

**1.A**  **Connector 1 (Black):**  
 Determine the type of installation:  
 INSTALLATION WITH DATA-LINK (See P.3)  
 INSTALLATION WITHOUT DATA-LINK (See P.3)

**1.B**  **Connector 2 (White):**  
 Make the connections associated with the vehicle in the VEHICLE FIT GUIDE (P.3)

**1.C**  **Connector 3 (White, located at the back of the module):**  
 Make the connections associated with the vehicle in the VEHICLE FIT GUIDE (P.3)

### CAN PROGRAMMING

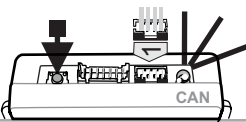
**2**  **Press** the programming switch while inserting the main wires harness (**CONN 1**) into the CAN module. The LED will illuminate to indicate you are in programming mode, release the programming button.

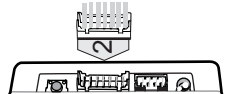
**3**  **Connect** the other connectors (**CONN. 2**)  
**WARNING:** Connector 2 can be easily plugged in backwards.

**4**  **Connect** the other connectors (**CONN. 3**)

**5**  Turn the key to the "ON" position.

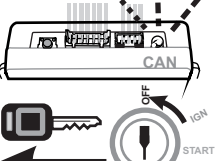
**6**  Once the LED starts to flash rapidly turn the key to the **OFF** position. The LED will turn off to indicate the module has been programmed.  
**The module is now ready for use.**

**7**  **Make the connections of the HONDA to the vehicle:**

**Connector 2 (White):**  
 (I) Locate the wiring type for the vehicle on the VEHICLE FIT GUIDE (P.3)  
 (II) Make the connections associated with the vehicle in the WIRING SCHEMATIC CONFIGURATION (P.3)

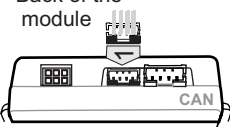
**8**  Back of the module  
 Connect the second Data-Link connector in the CAN (**CONN. 4** Located at the back)

### HONDA PROGRAMMING

**9**  Press and hold the programming button.

 **Connector 1 (Black):**  
 Connect the Data-Link connector directly in the CAN module.

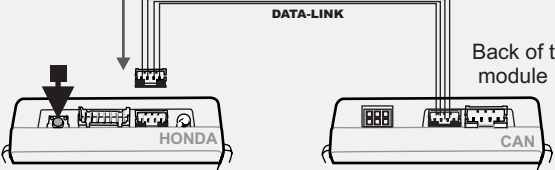
**10**  DATA-LINK  
 Back of the module

**11**  Insert **connector 2** into the **HONDA** interface.

**12**  Release the programming button when the LED turns ON.

**13**  Turn the **Ignition to the ON** position.

**14**  The LED flashes 10 times, **the module is programmed.**

**15**  Turn the Ignition key to **OFF** position.

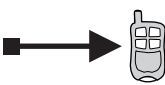
**16**  Remove the key and start the vehicle using the remote starter to ensure functionality.

Neither the manufacturer or distributor of this module is responsible of damages of any kind indirectly or directly caused by this module, except for the replacement of this module in case of manufacturing defects. This module must be installed by qualified technician. This instruction guide may change without notice. Visit [www.ifar.ca](http://www.ifar.ca) to get latest version.



## INSTRUCTIONS D'INSTALLATION ET DE PROGRAMMATION

### 1 Effectuez les connexions du CAN au véhicule:

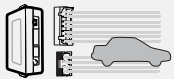

**Connecteur 1 (Noir):**  
Déterminez le type d'installation (**Data-Link** ou **non Data-Link**)  
Pour l'installation Data-Link assurez vous de la présence du connecteur Data-Link sur le démarreur. (P.3).  
Pour installation non Data-Link (P.3).



**1.B Connecteur 2 (Blanc):**  
Déterminez le type de branchement selon votre véhicule  
(Voir GUIDE DES VOITURES, P.3)  
Effectuez les branchements selon le type d'installation  
(Voir SCHÉMA DE BRANCHEMENT, P.3).



**1.C Connecteur 3 (Blanc, situé au dos du module):**  
Déterminez le type de branchement selon votre véhicule  
(Voir GUIDE DES VOITURES, P.3)  
Effectuez les branchements selon le type d'installation  
(Voir SCHÉMA DE BRANCHEMENT, P.3).

### PROGRAMMATION CAN

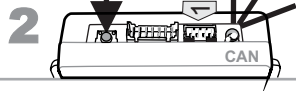

**2 Maintenez le bouton de programmation enfoncé** en insérant le **connecteur 1** dans le CAN.  
Le DEL s'allume pour indiquer le début de la programmation, **relâchez le bouton de programmation.**

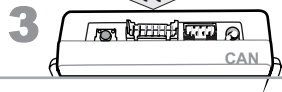

3 Branchez le connecteur 2 (**CONN. 2**)



4 **ATTENTION: Ne pas brancher le connecteur à l'envers.**

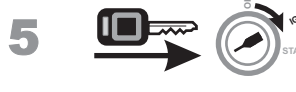

5 Branchez le connecteur 3 (**CONN. 3**)

5 Tournez la clef en position **ignition**.

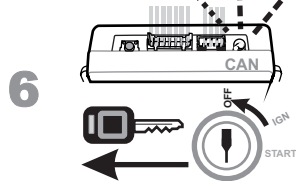

6 Lorsque le DEL clignote rapidement, **tournez la clef en position OFF.**  
**Le DEL s'éteint pour indiquer que le module est programmé.**

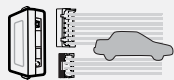

### Effectuez les connexions du HONDA au véhicule:

7



**Connecteur 2 (Blanc):**  
Déterminez le type de branchement selon votre véhicule  
(Voir GUIDE DES VOITURES, P.3).  
Effectuez les branchements selon le type d'installation  
(Voir SCHÉMA DE BRANCHEMENT, P.3).

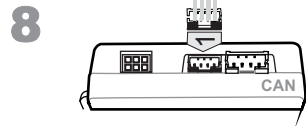

8 Branchez le 2ieme connecteur Data-Link dans le CAN (**CONN. 4** Situé au verso)

Dos du module

### PROGRAMMATION HONDA

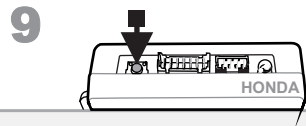

9 Maintenir le bouton de programmation du HONDA enfoncé.



**Connecteur 1 (Noir):**  
Branchez le connecteur Data-Link directement dans le module CAN

10

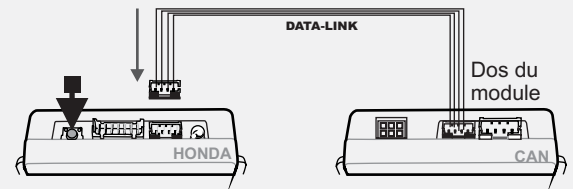

Dos du module

11

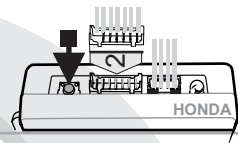

11 Insérez le **connecteur 2** dans le module **HONDA**.

12

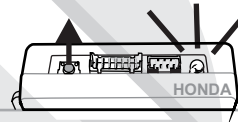

12 Lorsque la DEL s'allume, relâchez le bouton de programmation.

13



13 Tourner la clef en position **ignition (ON)**.

14

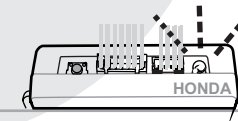

14 Le DEL clignote 10 fois.  
**Le module est programmé.**

15



15 Tournez la clef à **OFF**.

16



16 Retirez la clé du barillet et démarrez le véhicule avec le démarreur à distance.



### WIRING SCHEMATIC CONFIGURATION | SCHÉMA DE BRANCHEMENT

#### CAN MODULE Type 1

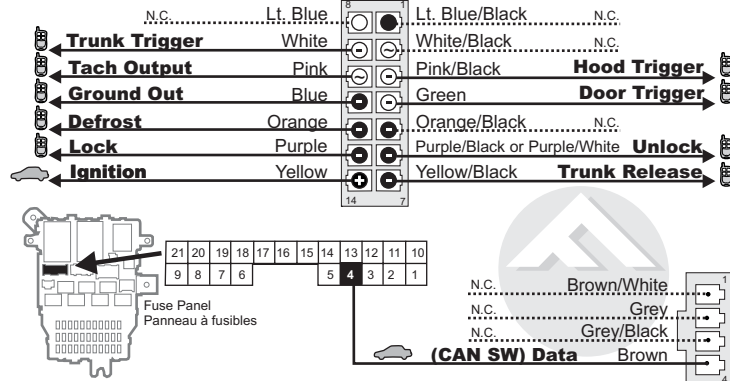

Wires located in driver kick panel, PIN-4, bottom row of 21-pin GREEN plug.  
Fils situés dans le panneau latéral du côté chauffeur, PIN-4, dernier rang du connecteur vert de 21 PINS.

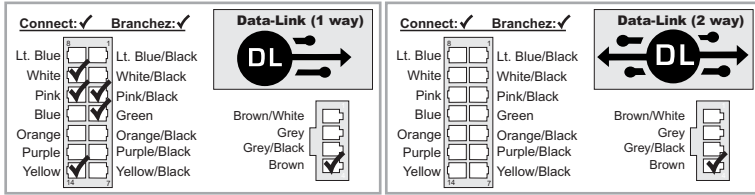

VEHICLES   VEHICULES	VEHICLE DATA WIRE COLOR   COULEUR DE FILS DATA
<b>Acura</b>	
TL	CAN SW: Brown/Black   Brun/Noir
TSX	CAN SW: Brown/Black   Brun/Noir
<b>Honda</b>	
Accord	CAN SW: Brown/Red   Brun/Rouge
Accord Hybrid	CAN SW: Brown/Red   Brun/Rouge
Ridgeline	CAN SW: Brown/Black   Brun/Noir

#### CAN MODULE Type 2

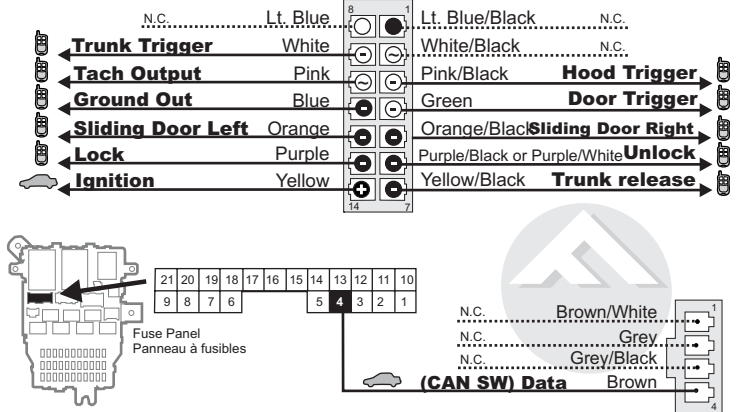

Wires located in driver kick panel, PIN-4, bottom row of 21-pin GREEN plug.  
Fils situés dans le panneau latéral du côté chauffeur, PIN-4, dernier rang de la connecteur vert de 21 PINS.

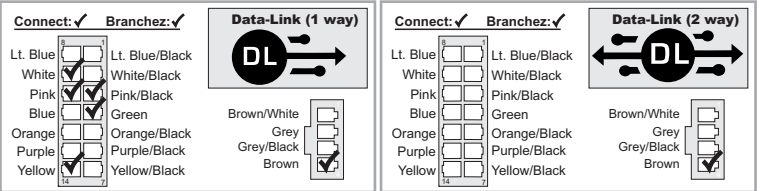

VEHICLES   VEHICULES	VEHICLE DATA WIRE COLOR   COULEUR DE FILS DATA
<b>Acura</b>	
MDX	CAN SW: Green   Vert
RL	CAN SW: Green   Vert
<b>Honda</b>	
Odyssey	CAN SW: Green/Red   Vert/Rouge

#### CAN MODULE Type 3

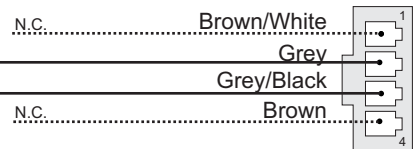
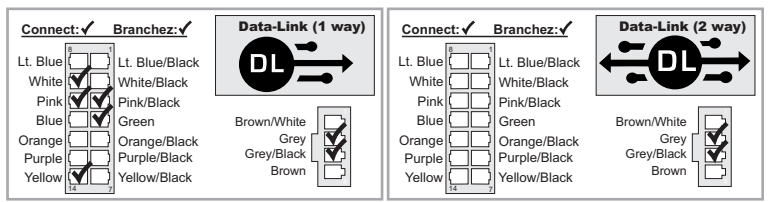
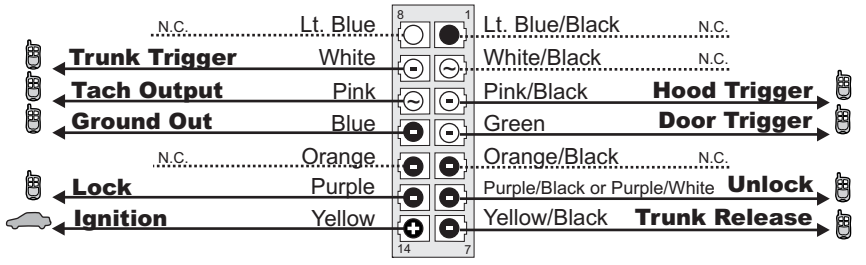
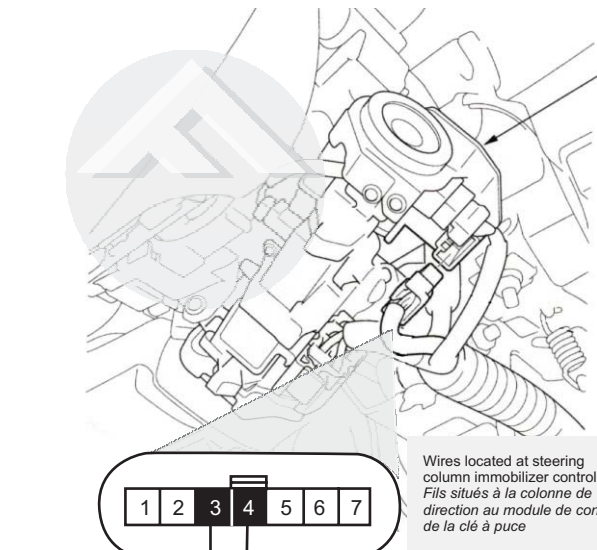

### INFORMATIONS

Ni le manufacturier, ni le distributeur ne se considèrent responsables des dommages causés ou ayant pu être causés, indirectement ou directement, par ce module, excepté le remplacement de ce module en cas de défectuosité de fabrication. Ce module doit être installé par un technicien qualifié. Ce guide d'instruction peut faire l'objet de changement sans préavis. Consultez le [www.ifar.ca](http://www.ifar.ca) pour voir la plus récente version.



Ni le manufacturier, ni le distributeur ne se considèrent responsables des dommages causés ou ayant pu être causés, indirectement ou directement, par ce module, excepté le remplacement de ce module en cas de défectuosité de fabrication. Ce module doit être installé par un technicien qualifié. Ce guide d'instruction peut faire l'objet de changement sans préavis. Consultez le [www.ifar.ca](http://www.ifar.ca) pour voir la plus récente version.



## VEHICLE FIT GUIDE | GUIDE DES VEHICULES

### HONDA MODULE Type 4

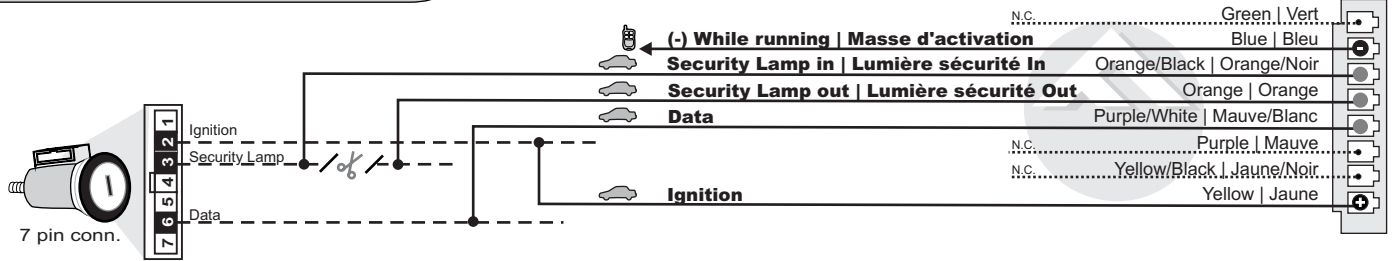

VEHICLES   VEHICULES	WIRE COLORS   COULEURS DE FILS					
Acura	Data	Synchro	Ignition	Security Lamp	Ground	12V
RL	Light Green Pin #6 Vert pâle Pin #6		Pink Rose	Red Pin #3 Rouge Pin #3		
TL	Red/Blue Pin #6 Rouge/Bleu Pin #6		Yellow/Black Jaune/Noir	Blue/Orange Pin #3 Bleu/Orange Pin #3	Brown/Yellow Pin #7 Brun/Jaune Pin #7	White Pin #1
TSX	Red/Blue Pin #6 Rouge/Bleu Pin #6		Yellow/Black Jaune/Noir	Blue/Orange Pin #3 Bleu/Orange Pin #3	Brown/Yellow Pin #7 Brun/Jaune Pin #7	White Pin #1
<b>Honda</b>						
Accord	Red/Blue Pin #6 Rouge/Bleu Pin #6		Black/Yellow Noir/Jaune	Blue/Orange Pin #3 Bleu/Orange Pin #3	Brown/Yellow Pin #7 Brun/Jaune Pin #7	White Pin #1
Odyssey	Red/Blue Pin #6 Rouge/Bleu Pin #6		Yellow/Black Jaune/Noir	Blue/Orange Pin #3 Bleu/Orange Pin #3	Black Pin #1 Noir Pin #1	
Ridgeline	Red/Blue Pin #6 Rouge/Bleu Pin #6		Green/Black Vert/Noir	Blue/Orange Pin #3 Bleu/Orange Pin #3	Brown/Yellow Pin #7 Brun/Jaune Pin #7	White Pin #1

### HONDA MODULE Type 5

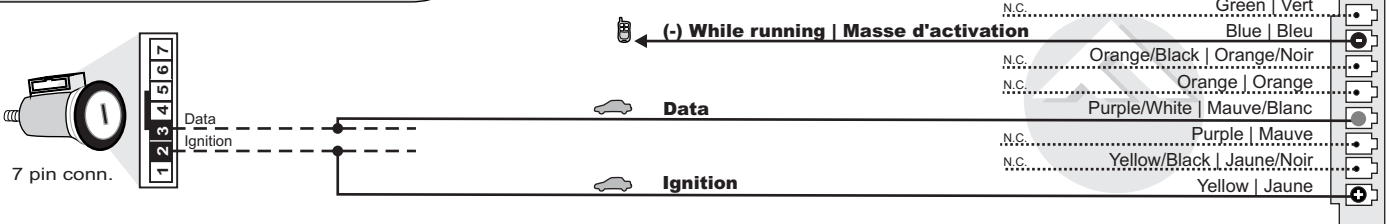

VEHICLES   VEHICULES	WIRE COLORS   COULEURS DE FILS					
Acura	Data	Synchro	Ignition	Security Lamp	Ground	12V
MDX	Small Light Green Pin #3 Petit vert pâle Pin #3		Brown Brun			

### HONDA MODULE Type 6

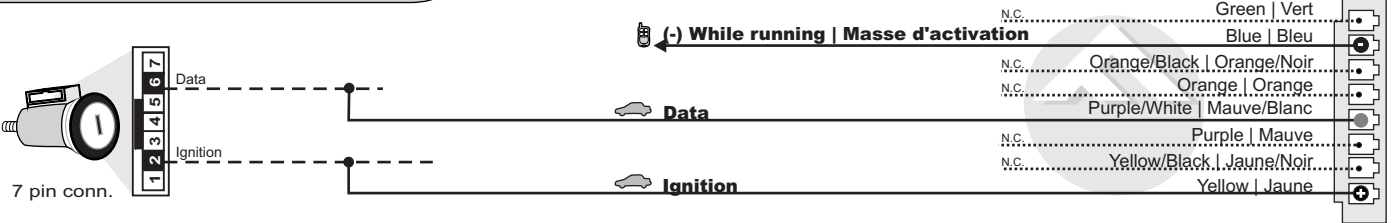

VEHICLES   VEHICULES	WIRE COLORS   COULEURS DE FILS					
Honda	Data	Synchro	Ignition	Security Lamp	Ground	12V
Accord	Light Green Pin #6 Vert Pâle Pin #6		Yellow Jaune			